



TECHNICAL DATA SHEET

DISHWASHER EQUIPMENT

IW100 GLASSWASHER



- Easy operation with digital control
- Aesthetic design
- Low cost spare parts
- Easy usage of control panel
- Low cost spare parts
- Genuine design of spray arms
- 3 washing programs



DISHWASHER EQUIPMENT IW100



AIM INDUSTRIAL KITCHEN EQUIPMENT
DAP VALLEY S BUILDING NO:10 KAGITHANE / ISTANBUL





TECHNICAL DATA SHEET

DIGITAL PANEL DETAILS

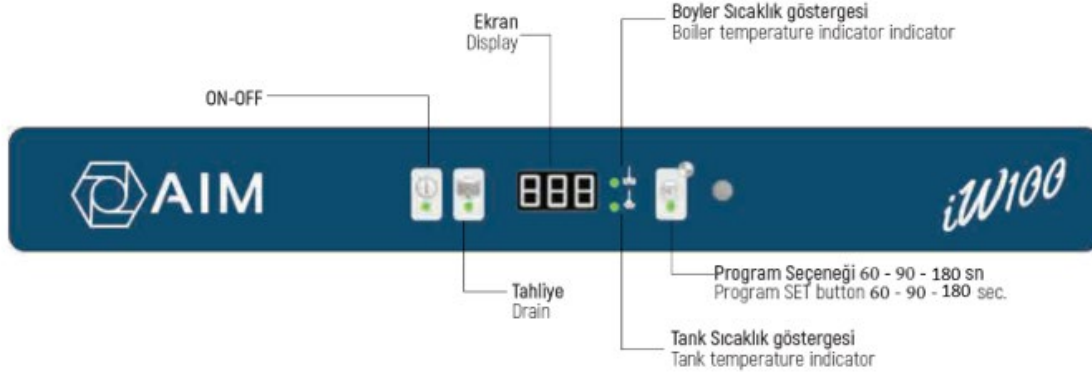

- **ON-OFF button:** It is used in order to turn on/off the machine. It lights green when machine is on operation, it lights red when machine is paused.
- **Drain button:** It is used in order to drain water from the tank. It will light green when drain is activated manually or automatically.
- **Display:** Displays tank temperature, boiler temperature, CLr, FILL, OPE, HZY, tBC and other warnings.
- **Tank temperature indicator:** The value on display belongs to the temperature of water in the tank. It lights green when it is active.
- **Boiler temperature indicator:** The value on display belongs to the temperature of water in the boiler. It lights green when it is active.
- **Program SET button:** Press the button in order to change or select the programs. 1. Program 60 sec. (Quick Wash) 2. Program 90 sec. (Regular Wash) 3. Program 180 sec. (Intensive Wash)

OPTIONS



DISHWASHER EQUIPMENT IW100





TECHNICAL DATA SHEET

GENERAL INFORMATION

- Hygienic Washing System: ✓
- External Dimensions(mm): 690x787x1475
- Packed Product Dimensions(mm): 700x797x1485
- Product Weight (kg): 90
- Packed Product Weight (kg): 100
- Basket Dimensions(mm): 500x500
- Capacity: 1000 plates/hour
- Number of Programs: 3
- Quick Washing Program P1: 60 second
- Regular Washing Program P2: 90 second
- Intensive Washing Program P3: 180 second
- Electrical Connection: 400V / 3N / 50Hz
- Cable Section: 3x2,5mm²
- Washing Tank Capacity: 70-37 liters
- Wash Resistance Power: 3Kw
- Washing Pump Power: 0.76kW
- Washing Water Temperature: 55°C
- Boiler Tank Capacity: 8-12 Liters
- Boiler Resistance Power: 9kW
- Water Consumption: 3lt/wash
- Rinse Water Temperature: 82°C
- Total Power: 9,70kW
- Sound Level: <63dB
- Water inlet Diameter: ¾" Inch
- What is supplied with the product: 1 Glass Basket, 1 Sprinkler Spoon Holder

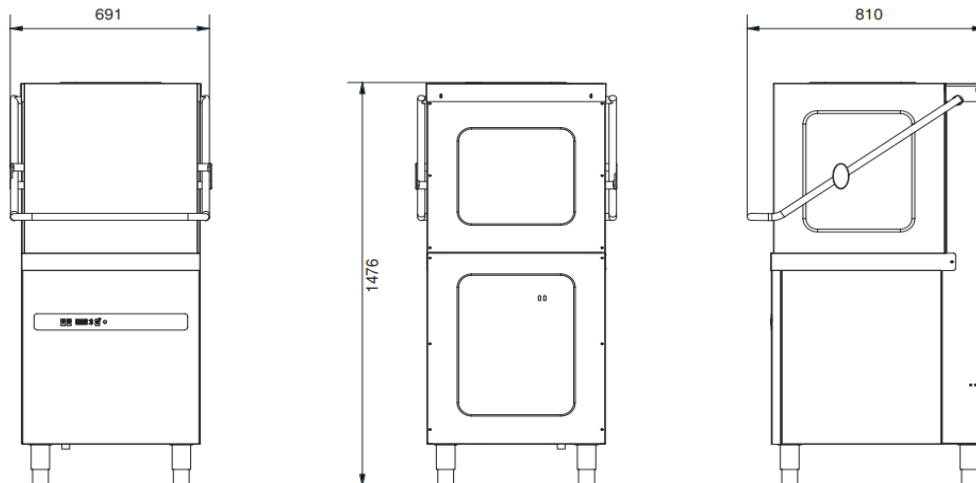

DISHWASHER EQUIPMENT IW100

