



## TECHNICAL DATA SHEET

### FAST FOOD EQUIPMENT

#### GAS SALAMANDER

- Ceramic burner
- Standard version on natural gas
- Height-adjustable collection tray for grease and water
- High-quality construction
- Made from stainless steel

**Model:** AIM GSL2

**Dimension (mm):** 650x430x600

**Weight(kg):** 38

**Pack. Dimension:** 550x600x640

**Pack. Weight (kg):** 40

**Power (kw):** 5,4

**Burner:** 2

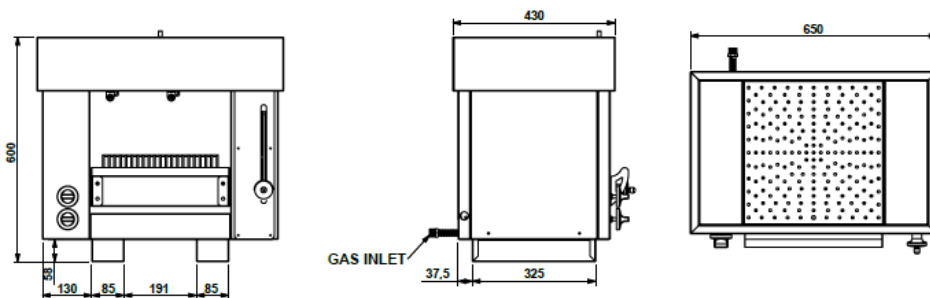
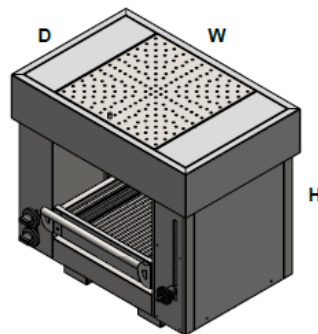

FAST FOOD EQUIPMENT AIM GSL2

