



## TECHNICAL DATA SHEET

### FAST FOOD EQUIPMENT

#### ELECTRIC SALAMANDER



- Thermostatic control.
- Height-adjustable collection tray for grease and water
- High-quality construction
- Made from stainless steel

**Model:** AIM ESL2

**Dimension (mm):** 450x500x540

**Weight(kg):** 35

**Pack. Dimension:** 550x600x640

**Pack. Weight (kg):** 37

**Power (kw):** 2,8

**Power Supply:** 220-240 V

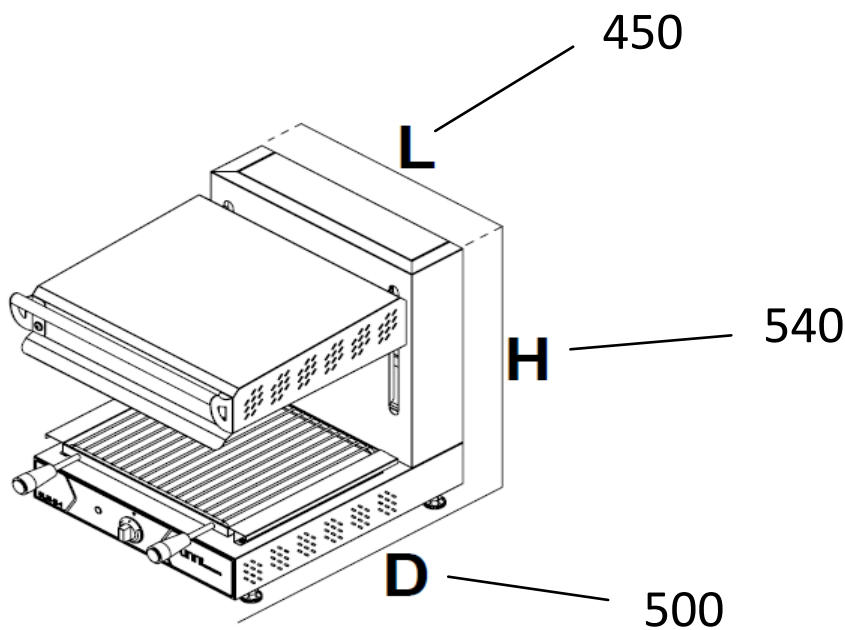

FAST FOOD EQUIPMENT AIM ESL2

