



TECHNICAL DATA SHEET

SPECIAL COLDLINE



AIM BTR3 COOLING BANQUET TROLLEY

- Designed to operate in 43°C ambient %65 humidity
- New design for equal temperature distribution
- Zero ODP Injected 42 kg/m³ Polyurethane Insulation
- Digital controller with easy read screen
- Ergonomic door and handle designed for ease of opening and cleaning
- Icecool refrigeration system designed to be most technologically advanced and energy efficient
- Hot gas defrost system
- Waste heat recovery condensate vaporiser system
- All refrigerators can be produced in marine version
- Marine version includes 'Icecool marine' system, legs and shelves
- 12 No's 2/1 Gn capacity



SPECIAL COLDLINE AIM BTR3





TECHNICAL DATA SHEET



GENERAL INFORMATION

Operating Temperature: -2/+8
Climate class: 5
Overall dimensions: 789x950x1785
Capacity: 525L
Capacity (GN 2/1-60): 12

CABINET CONSTRUCTION

Exterior Material: AISI 304 Stainless Steel
Back Material: Galvanized steel
Interior Material: AISI 304 Stainless Steel
Drain: ✓
LED lighting Eclairage LED: X
Insulation: Polyurethane with high density
40kg/m³, CFCs free, zero ODP and low GWP
Insulation thickness(mm): 50
Blowing Agent: HFO

REFRIGERATION

Thermostat: Touch screen- IP65
Refrigeration system: Split system
Defrost: Resistance
Expansion Device: Capillary
Fans: ✓
Condensation: Forced air
Evaporation: With fan
Condensate pan: Hot gas condensation pan

TECHNICAL FEATURES

Gas Refrigerant: R134A
Power Supply: 230V / 1 / 50 Hz

CRATING

Crated dimensions L x l x H (mm):839x1000x2035
Net Weight (kg): 131
Crated Weight (kg): 141



SPECIAL COLDLINE AIM BTR3





TECHNICAL DATA SHEET

NEW CONDENSER SYSTEM

Stayclear condenser



CLASSIC



AIMCLEAR

SAVING ENERGY

Eco friendly, HFC – free polyurethane insulation providing low energy consumption



EVAPARATOR DOES NOT SNOW THROUGH HOT GAS DEFROST



CLASSIC

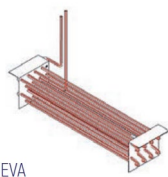

AIMEVA

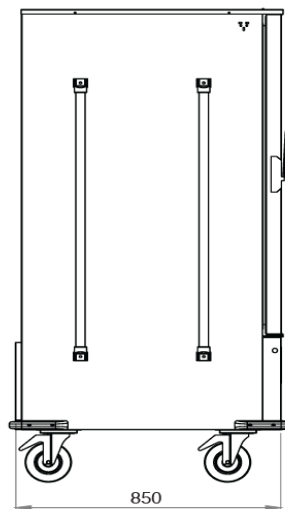
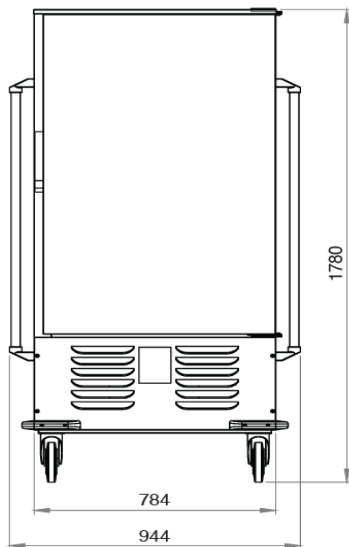

SPECIAL GOLDLINE AIM BTR3

