



TECHNICAL DATA SHEET

600 SERIES HOT LINE

GAS LAVASTONE GRILL



AIM ALG86

- With its stainless steel construction, it is long-lasting and easy to use. It is cleanable and hygienic.
- Ergonomic that provides convenience to the user in every aspect. It has a design.
- Device depth is 600 mm.
- The device is a countertop.
- Height adjustable feet on the device available.
- Front panel sheet of the device is 1mm AISI 304, Top plate sheet is 1mm AISI 304, body side panels 1 mm AISI 430, rear chimney construction covering sheet 1 mm AISI 430, chimney ventilation sheet made of 1.5 mm AISI 304 material produced.
- Your device uses Natural Gas (NG) and Liquid Propane Gas (LPG). It can work with. For this purpose, use other gas in the spare bag. There are conversion injectors to the type this the procedure must be carried out by a competent person.
- Cooking speed can be selected as high flame or low flame. There is 1 adjustable gas tap.
- Burner in the device that provides high calories is used.
- Homogeneous heat thanks to each independent burner distribution is provided. Control system with pilot and thermocouple in the device There are. Flame thanks to thermocouple When it goes off, the gas coming to the device automatically is cut.
- Magneto lighter to light the pilot there are.
- The cooking grill part of the device is AISI 304 Made of twisted sheet metal.
- The device has a 2-stage operation via the two arms in the front. The cooking surface can be adjusted according to the user's wishes adjustable.
- The cooking upper part can be easily removed and it is cleanable.
- The device has a 3 kg lava stone capacity chamber there are.
- When the oil reservoir is full and not emptied Thanks to the overflow holes in the front It overflows from its chamber and there is oil inside the device gets blocked.
- Easily removed from the drawer and cleaned it is in structure.



600 SERIES HOT LINE AIM ALG86



TECHNICAL DATA SHEET

ÖN / FRONT

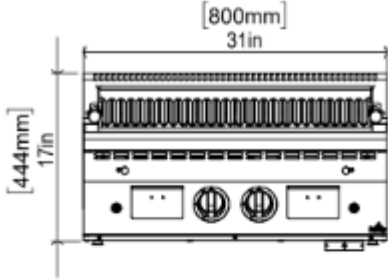

SAG / RIGHT

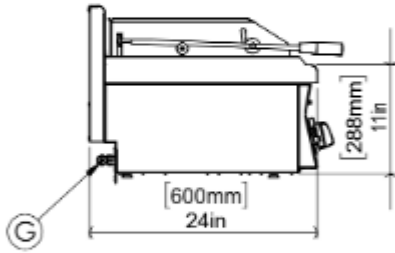

ÜST / TOP

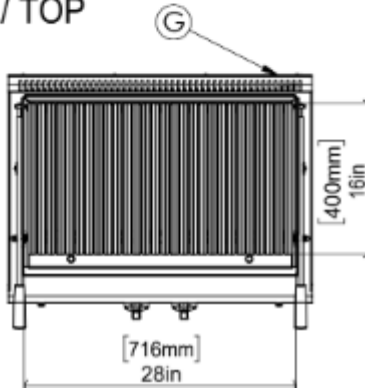

GENERAL INFORMATION

Model: AIM ALG86
 Dimension: 800x600x300
 Net Weight (kg):62
 Gaz Enter: R1/2"
 Cooking Area(mm): 695x405

GAS INFORMATION

NG	G20	G20	G25
	20 mbar	25 mbar	25 mbar
QUANTITY OF HEAT (KW) (HI)	13	13	12,98
GAS CONSUMPTION	1,424 m3/h	1,428 m3/h	1,514 m3/h

LPG	G30	G30	G30	G31
	30 mbar	37 mbar	50 mbar	37 mbar
QUANTITY OF HEAT (KW) (HI)	13	13,2	13,4	13,6
GAS CONSUMPTION	1024 g/h	1024 g/h	1024 g/h	1008 g/h

PACKAGE INFORMATION

Dimension: 900x690x625
 Package Weight (kg): 75
 Volume (m³): 0,39 m³

