



TECHNICAL DATA SHEET

600 SERIES HOT LINE



AIM AGW86
GAS WOK COOKER

- With its stainless steel construction, it is long-lasting and easy to use. It is cleanable and hygienic.
- Ergonomic that provides convenience to the user in every aspect. It has a design.
- Device depth is 600 mm.
- The device is a countertop.
- Height adjustable feet on the device available.
- Front panel sheet of the device is 1mm AISI 304, Top plate sheet is 1mm AISI 304, body side panels 1 mm AISI 430, rear chimney construction covering sheet 1 mm AISI 430, chimney ventilation sheet made of 1.5 mm AISI 304 material produced.
- High calorie burners in the device is used.
- Cooker speed as high flame or low flame adjustable, there are 2 gas taps. 2 independent control over the device with 2 gas taps can be made.
- Piloted and thermocouple control system is available. Flame thanks to thermocouple When it goes out, the gas coming to the device automatically is cut.
- Cast iron that retains heat on the device features.
- Pilot can be lit from outside with external lighter.
- Crumb collection drawer at the bottom of the device are available.
- Top table is formed by applying press printing manufactured.
- Natural Gas (NG) and Liquid Propane Gas (LPG) can work with For this, other gas is included in the spare pouch. Type conversion injectors are available. These the procedure must be carried out by a competent person.



600 SERIES HOT LINE AIM AGW86



TECHNICAL DATA SHEET

ÖN / FRONT

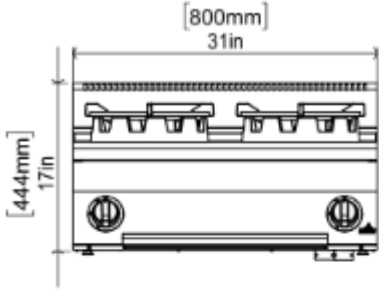

SAG / RIGHT

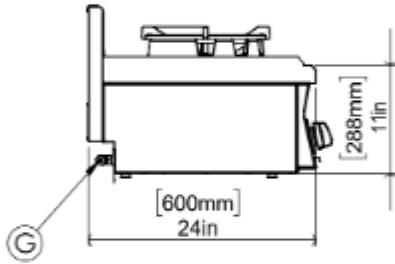

ÜST / TOP

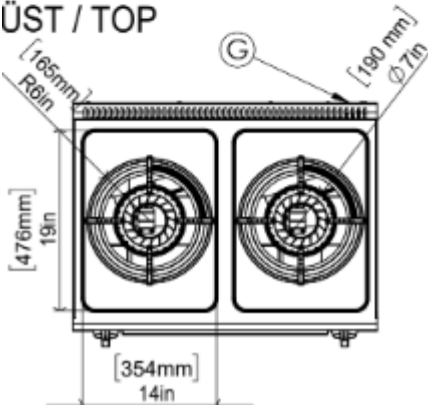

GENERAL INFORMATION

Model: AIM AGW86

Dimension: 800x600x300

Gaz Enter: R1/2"

Net Weight (kg): 67

GAS INFORMATION

NG	G20 20 mbar	G20 25 mbar	G25 25 mbar
QUANTITY OF HEAT (KW) (HI)	20	20	19,4
GAS CONSUMPTION	2,114 m3/h	2,114 m3/h	2,386 m3/h

LPG	G30 30 mbar	G30 37 mbar	G30 50 mbar	G31 37 mbar
QUANTITY OF HEAT (KW) (HI)	20	20	20	20
GAS CONSUMPTION	1576 g/h	1576 g/h	1576 g/h	1552 g/h

PACKAGE INFORMATION

Dimension: 900x690x625

Package Weight (kg): 80

Volume (m³): 0,39 m³