



TECHNICAL DATA SHEET

600 SERIES HOT LINE GAS FRYER



AIM AGF86

- With its stainless steel construction, it is long-lasting and easy to use. It is cleanable and hygienic.
- Ergonomic that provides convenience to the user in every aspect. It has a design.
- Device depth is 600 mm.
- The device is a countertop.
- Height adjustable feet on the device available.
- Front panel sheet of the device is 1mm AISI 304, Top plate sheet is 1mm AISI 304, body side panels 1 mm AISI 430, rear chimney construction covering sheet 1 mm AISI 430, chimney ventilation sheet made of 1.5 mm AISI 304 material produced.
- High calorie burners in the device is used.
- The device; Oil Reservoir: 2X15lt recommended max. Oil capacity 2x11lt and min. Oil capacity 2x9lt
- With the 7-stage thermostat on the device it allows you to adjust the temperature as desired. Control system with pilot and thermocouple in the device there are. Flame thanks to thermocouple when it goes off, the gas coming to the device automatically is cut.
- Thermostat and gas tap are included in the device and also has the pilot on the gas tap. It has a lighter feature to ignite it.
- The basket used in the device measures 2 pieces 215x260x95 mm.
- Locked discharge valve mechanism in the device thanks to this, safe unloading is ensured. User it cannot be opened or discharged without its control.
- The top table is formed by applying press pressure produced.
- Your device uses Natural Gas (NG) and Liquid Propane Gas (LPG). It can work with. For this purpose, use other gas in the spare bag. There are conversion injectors to the type this The procedure must be carried out by a competent person.



600 SERIES HOT LINE AIM AGF86



TECHNICAL DATA SHEET

ÖN / FRONT

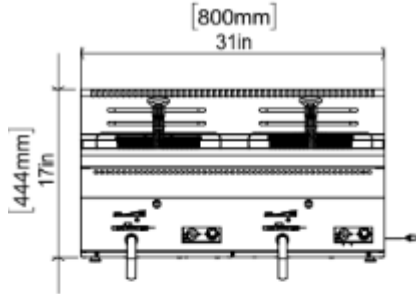

GENERAL INFORMATION

Model: AIM AGF86

Dimension: 800x600x300

Gas Enter: R1/2"

Net Weight (kg):44

Oil Capacity (lt): 2x9 min; 2x11 max

Oil Chamber (lt): 2x15lt

SAĞ / RIGHT

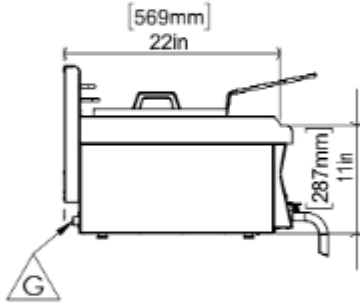

GAS INFORMATION

NG	G20	G20	G25
	20 mbar	25 mbar	25 mbar
QUANTITY OF HEAT (KW) (HI)	10,6	10,6	10,6
GAS CONSUMPTION	1,084 m3/h	1,130 m3/h	1,310 m3/h

LPG	G30	G30	G30	G31
	30 mbar	37 mbar	50 mbar	37 mbar
QUANTITY OF HEAT (KW) (HI)	10,6	10,6	10,6	10,6
GAS CONSUMPTION	336 g/h	336 g/h	304 g/h	426 g/h

ÜST / TOP

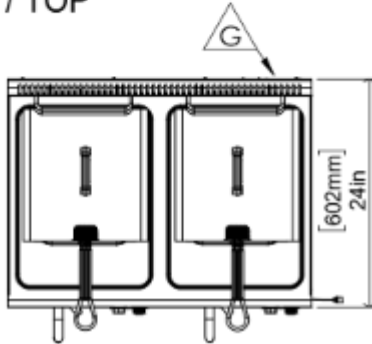

PACKAGE INFORMATION

Dimension: 900x690x625

Package Weight (kg): 57

Volume (m³): 0,39 m³

