



TECHNICAL DATA SHEET

600 SERIES HOT LINE

GAS FRYERS



AIM AGF46

- With its stainless steel construction, it is long-lasting and easy to use. It is cleanable and hygienic.
- Ergonomic that provides convenience to the user in every aspect. It has a design.
- Device depth is 600 mm.
- The device is a countertop.
- Height adjustable feet on the device available.
- Front panel sheet of the device is 1mm AISI 304, Top plate sheet is 1mm AISI 304, body side panels 1 mm AISI 430, rear chimney construction covering sheet 1 mm AISI 430, chimney ventilation sheet made of 1.5 mm AISI 304 material produced.
- High calorie burners in the device is used.
- The device; Oil Reservoir: 15lt Recommended max. Oil capacity 11lt and min. Oil capacity 9lt
- With the 7-stage thermostat on the device it allows you to adjust the temperature as desired. Control system with pilot and thermocouple in the device there are. Flame thanks to thermocouple when it goes off, the gas coming to the device automatically is cut.
- Thermostat and gas tap are included in the device and also has the pilot on the gas tap. It has a lighter feature to ignite it.
- The basket used in the device measures 215x260x95 mm.
- Locked discharge valve mechanism in the device thanks to this, safe unloading is ensured. User it cannot be opened or discharged without its control.
- The top table is formed by applying press pressure produced.
- Your device uses Natural Gas (NG) and Liquid Propane Gas (LPG). It can work with . For this purpose, use other gas in the spare bag. There are conversion injectors to the type this The procedure must be carried out by a competent person.



600 SERIES HOT LINE AIM AGF46



TECHNICAL DATA SHEET

ÖN / FRONT

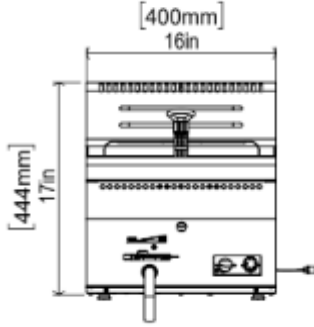

SAG / RIGHT

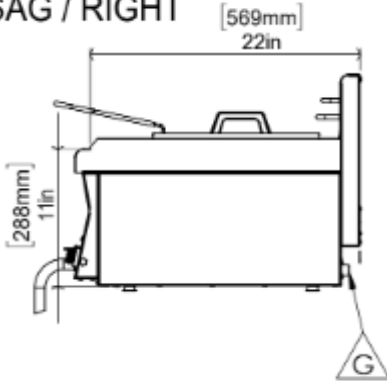

ÜST / TOP

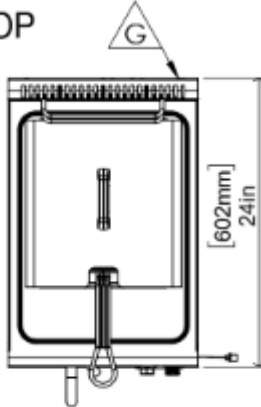

GENERAL INFORMATION

Model: AIM AGF46
 Dimension: 400x600x300
 Gaz Enter: R1/2"
 Net Weight (kg): 25
 Oil Capacity (lt): 9 min; 11 max
 Oil Chamber (lt): 15lt

GAS INFORMATION

NG	G20 20 mbar	G20 25 mbar	G25 25 mbar
QUANTITY OF HEAT (KW) (HI)	5,3	5,3	5,3
GAS CONSUMPTION	0,542 m3/h	0,565 m3/h	0,655 m3/h

LPG	G30 30 mbar	G30 37 mbar	G30 50 mbar	G31 37 mbar
QUANTITY OF HEAT (KW) (HI)	5,3	5,3	5,3	5,3
GAS CONSUMPTION	168 g/h	168 g/h	152 g/h	213 g/h

PACKAGE INFORMATION

Dimension: 500x690x575
 Package Weight (kg): 31
 Volume (m³): 0,20 m³

