



TECHNICAL DATA SHEET

600 SERIES HOT LINE



AIM AEF66

ELECTRICAL FRYERS

- With its stainless steel construction, it is long-lasting and easy to use. It is cleanable and hygienic.
- Ergonomic that provides convenience to the user in every aspect. It has a design.
- Device depth is 600 mm.
- The device is a countertop.
- Height adjustable feet on the device available.
- Front panel sheet of the device is 1mm AISI 304, Top plate sheet is 1mm AISI 304, body side panels 1 mm AISI 430, rear chimney construction covering sheet 1 mm AISI 430, chimney ventilation sheet made of 1.5 mm AISI 304 material produced.
- The device; Oil Reservoir: 2x11 Lt. Recommended Max. Oil capacity 2x9 Lt. and Min. Oil capacity 2x4,5 Lt.
- Oil temperature; With thermostat between 100°C-190°C is controlled
- The device has overheating protection as standard for safety purposes. There is a limit thermostat for protection against.
- Thanks to the locked discharge valve mechanism in the device. Safe discharge from the drain tap on the front of the device is provided. Opening and emptying without user control It cannot be done.
- The resistances in the device move upwards from the bathtub. Has the ability to. In this way, the product can be easily can be cleaned. Resistors are in the above position. Electrical energy is cut off thanks to the safety switch.
- The basket used in the device measures 185x260x95 mm. 2 pieces are used.
- There are two different buttons next to the heat adjustment button on the device. There is a colored signal lamp. Green signal lamp it indicates that the device is receiving electricity. Yellow signa the lamp indicates that the resistance is active. It burns until it reaches the desired temperature. It will turn off when reached.
- The top table is formed by applying press pressure produced.



600 SERIES HOT LINE AIM AEF66



TECHNICAL DATA SHEET

ÖN / FRONT

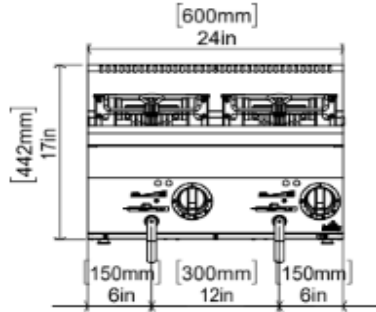

SAG / RIGHT

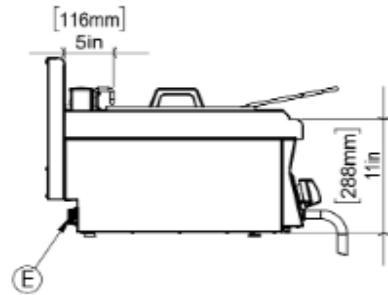

ÜST / TOP

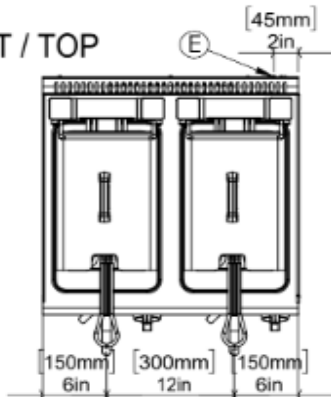

GENERAL INFORMATION

Model: AIM AEF66

Dimension: 600x600x300

Net Weight (kg):36

Oil Capacity (lt): 2x4,5 min; 2x9 max

Oil Chamber (lt): 2x11lt

Thermostat Working Range: 100 °C min; 190 °C max

ELECTRICAL INFORMATION

Voltage: 380-415V

Electric power: 15 kW

Amper: 68,2A

Cable Section: 5x2,5 mm² TTR

Frequency: 50-60hz

Protection Class: IPX4

Min/max internal humidity:70%/85%

Control type: Manual

PACKAGE INFORMATION

Dimension: 700x690x575

Package Weight (kg): 44

Volume (m³): 0,28 m³

Important Note: The current value given for the device is based on the amount drawn by the device. Is the current value. Cable distance to be connected to the device. The fuse amperage value that should be used according to the length must be determined by a competent electrician.