



## TECHNICAL DATA SHEET

### LOW LEVEL SERIES



AIM 247LF4

LOW LEVEL FREEZER -W/4 DOORS

- Designed to operate in 43°C ambient %65 humidity
  - New design for equal temperature distribution
  - Zero ODP Injected 42 kg/m<sup>3</sup> Polyurethane Insulation
  - Digital controller with easy read screen
  - Ergonomic door and handle designed for ease of opening and cleaning
  - Icecool refrigeration system designed to be most technologically advanced and energy efficient
  - Hot gas defrost system
  - Waste heat recovery condensate vaporiser system
  - All refrigerators can be produced in marine version
- 
- For 1/1 drawers; 1/1-200mm Gn capacity
  - For 1/2 drawers; 1/1-100mm Gn capacity



AIM

LOW LEVEL SERIES AIM 247LF4

AIM





## TECHNICAL DATA SHEET

Operating Temperature: -10/-22 °C  
Capacity: 450L  
Overall dimensions: 2400x700x600

### CABINET CONSTRUCTION

Exterior Material: AISI 430 Stainless Steel  
Back Material: Galvanized steel  
Interior Material: AISI 430 Stainless Steel  
Drain: ✓  
LED lighting Eclairage LED: X  
Insulation: Polyurethane with high density  
40kg/m<sup>3</sup>, CFCs free, zero ODP and low GWP  
Insulation thickness(mm): 50  
Blowing Agent: HFO  
Doors: 4  
Door Construction: Pressed hinged door. Easy  
to replace door gasket that does not require  
cleaning  
Door Lock: Optional  
Door Frame Heaters: X

### FEATURES

Shelving: 1x2  
Shelves dimensions LxD: 470x405  
Legs, casters: Stainless steel legs,  
height adjustable (130-180mm)

### REFRIGERATION

Thermostat: Touch screen- IP65  
Refrigeration system: Split system  
Defrost: Resistance  
Expansion Device: Capillary  
Fans: ✓  
Condensation: Forced air  
Evaporation: With fan  
Condensate pan: Hot gas condensation pan

### TECHNICAL FEATURES

Gas Refrigerant: R404A  
Power Supply: 230V / 1 / 50 Hz

### CRATING

Crated dimensions L x l x H (mm):2450x750x850  
Net Weight (kg): 177  
Crated Weight (kg): 187



LOW LEVEL SERIES AIM 247LF4





# TECHNICAL DATA SHEET

## NEW CONDENSER SYSTEM

Stayclear condenser



CLASSIC



AIMCLEAR

## SAVING ENERGY

Eco friendly, HFC – free polyurethane insulation providing low energy consumption



## EVAPARATOR DOES NOT SNOW THROUGH HOT GAS DEFROST



CLASSIC



AIMEVA

## PERFECT COOLING SYSTEM

More efficient air circulation with one piece evaporator



CLASSIC



AIMICE

## EXTRA INTERNAL VOLUME

Easy to use and extra internal volume by the help of the horizontally positioned evaporator



CLASSIC



AIMEX

## PERFECT HEAT CONTROL

With our under counter insulation solution, temperature control is provided perfectly.



CLASSIC



AIM HEAT

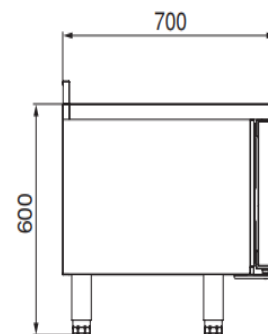
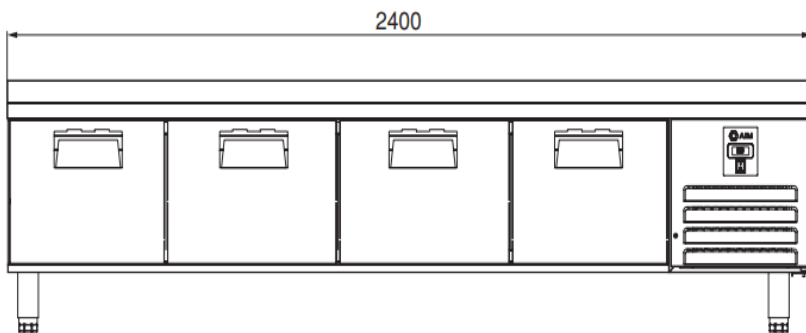

LOW LEVEL SERIES AIM 247LF4



AIM INDUSTRIAL KITCHEN EQUIPMENT  
DAP VALLEY S BUILDING NO:10 KAGITHANE / ISTANBUL

