



## TECHNICAL DATA SHEET

### COUNTER TYPE SERIES



AIM 157R3

COUNTER TYPE REFRIGERATOR -W/2 DOORS

- Designed to operate in 43°C ambient %65 humidity
- New design for equal temperature distribution
- Zero ODP Injected 42 kg/m<sup>3</sup> Polyurethane Insulation
- Digital controller with easy read screen
- Ergonomic door and handle designed for ease of opening and cleaning
- Icecool refrigeration system designed to be most technologically advanced and energy efficient
- Hot gas defrost system
- Waste heat recovery condensate vaporiser system
- All refrigerators can be produced in marine version
- For 1/2 drawers; 1/1-150mm Gn capacity
- For 1/3 drawers; 1/1-100mm Gn capacity



COUNTER TYPE SERIES AIM 157R3



AIM INDUSTRIAL KITCHEN EQUIPMENT  
DAP VALLEY S BUILDING NO:10 KAGITHANE / ISTANBUL





## TECHNICAL DATA SHEET

### GENERAL INFORMATION

Operating Temperature: -2/+8 °C  
Climate class: 5  
Capacity: 330L  
Overall dimensions: 1500x700x850

### CABINET CONSTRUCTION

Exterior Material: AISI 304 Stainless Steel  
Back Material: Galvanized steel  
Interior Material: AISI 304 Stainless Steel  
Drain: ✓  
LED lighting eclairage LED: X  
Insulation: Polyurethane with high density  
40kg/m<sup>3</sup>, CFCs free, zero ODP and low GWP  
Insulation thickness(mm): 50  
Blowing Agent: HFO  
Doors: 2  
Door Construction: Pressed hinged door. Easy  
to replace door gasket that does not require  
cleaning  
Door Lock: Optional  
Door Frame Heaters: X

### FEATURES

Shelving: 1x2  
Shelves dimensions LxD: 470x505  
Legs, casters: Stainless steel legs,  
height adjustable (130-180mm)

### REFRIGERATION

Thermostat: Touch screen- IP65  
Refrigeration system: Split system  
Defrost: Resistance  
Expansion Device: Capillary  
Fans: ✓  
Condensation: Forced air  
Evaporation: With fan  
Condensate pan: Hot gas condensation pan

### TECHNICAL FEATURES

Gas Refrigerant: R134A  
Charge de gas (gr): 240  
Power Supply: 230V / 1 / 50 Hz  
Refrigeration Capacity (W): 570  
Power (W): 340  
Amps (A): 1,56  
Energy Consumption (kWh/24h): 3,96

### CRATING

Crated dimensions L x l x H (mm):1550x750x1100  
Net Weight (kg): 100  
Crated Weight (kg): 110



COUNTER TYPE SERIES AIM 157R3





## TECHNICAL DATA SHEET

### NEW CONDENSER SYSTEM

Stayclear condenser



CLASSIC



AIMCLEAR

### SAVING ENERGY

Eco friendly, HFC – free polyurethane insulation providing low energy consumption



### EVAPARATOR DOES NOT SNOW THROUGH HOT GAS DEFROST



CLASSIC

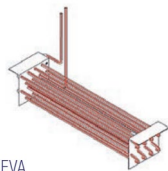

AIMEVA

### PERFECT COOLING SYSTEM

More efficient air circulation with one piece evaporator



CLASSIC



AIMEICE

### EXTRA INTERNAL VOLUME

Easy to use and extra internal volume by the help of the horizontally positioned evaporator



CLASSIC



AIMEX

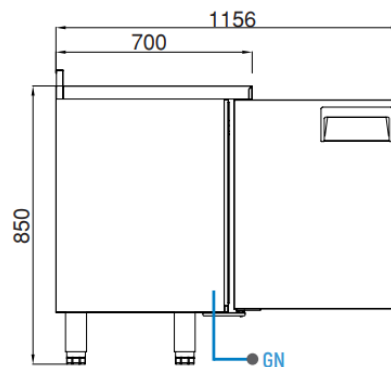
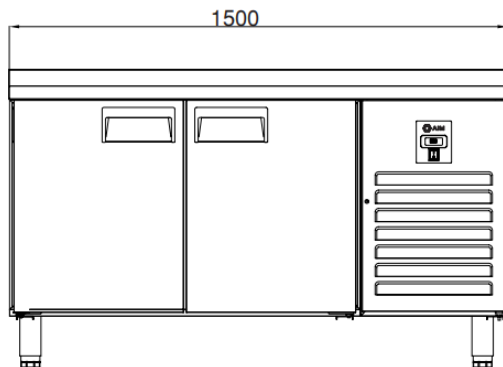

COUNTER TYPE SERIES AIM 157R3



AIM INDUSTRIAL KITCHEN EQUIPMENT  
DAP VALLEY S BUILDING NO:10 KAGITHANE / ISTANBUL

