



## TECHNICAL DATA SHEET

### SPECIAL COLDLINE



AIM 157PF4

PREPARING TABLE REFRIGERATOR

- Designed to operate in 43°C ambient %65 humidity
- New design for equal temperature distribution
- Zero ODP Injected 42 kg/m<sup>3</sup> Polyurethane Insulation
- Digital controller with easy read screen
- Ergonomic door and handle designed for ease of opening and cleaning
- Icecool refrigeration system designed to be most technologically advanced and energy efficient
- Hot gas defrost system
- Waste heat recovery condensate vaporiser system
- All refrigerators can be produced in marine version
- 14 No's 1/4-100mm Gn capacity



SPECIAL COLD LINE AIM 157PF4



AIM INDUSTRIAL KITCHEN EQUIPMENT  
DAP VALLEY S BUILDING NO:10 KAGITHANE / ISTANBUL



## TECHNICAL DATA SHEET

### GENERAL INFORMATION

Operating Temperature: -2/+8 °C  
Climate class: 5  
Capacity: 330L  
Capacity (GN 1/6-150): 12  
Overall dimensions: 1500x700x1300

### CABINET CONSTRUCTION

Exterior Material: AISI 430 Stainless Steel  
Back Material: Galvanized steel  
Interior Material: AISI 430 Stainless Steel  
Drain: ✓  
LED lighting Eclairage LED: X  
Insulation: Polyurethane with high density  
40kg/m<sup>3</sup>, CFCs free, zero ODP and low GWP  
Insulation thickness(mm): 50  
Blowing Agent: HFO

### FEATURES

Shelving: 1x2  
Shelves dimensions LxD: 470x405  
Legs, casters: Stainless steel legs,  
height adjustable (130-180mm)

### REFRIGERATION

Thermostat: Touch screen- IP65  
Refrigeration system: Split system  
Defrost: Resistance  
Expansion Device: Capillary  
Fans: ✓  
Condensation: Forced air  
Evaporation: With fan  
Condensate pan: Hot gas condensation pan

### TECHNICAL FEATURES

Gas Refrigerant: R134A  
Power Supply: 230V / 1 / 50 Hz

### CRATING

Crated dimensions L x l x H (mm):1550x750x1550  
Net Weight (kg): 135  
Crated Weight (kg): 145





# TECHNICAL DATA SHEET

## NEW CONDENSER SYSTEM

Stayclear condenser



CLASSIC



AIMCLEAR

## SAVING ENERGY

Eco friendly, HFC – free polyurethane insulation providing low energy consumption



## EVAPARATOR DOES NOT SNOW THROUGH HOT GAS DEFROST

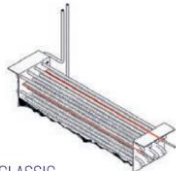

CLASSIC



AIMEVA

## PERFECT COOLING SYSTEM

More efficient air circulation with one piece evaporator



CLASSIC



AIMEVA

## EXTRA INTERNAL VOLUME

Easy to use and extra internal volume by the help of the horizontally positioned evaporator



CLASSIC



AIMEVA

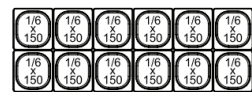
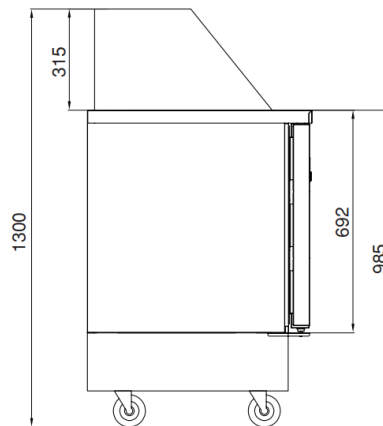
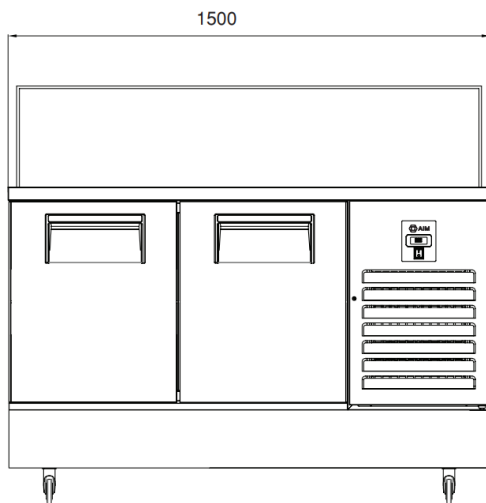

SPECIAL COLD LINE AIM 157PF4

