



## TECHNICAL DATA SHEET

### 600 SERIES HOT LINE

GAS GRILLS – ½ RIBBED ½ SMOOTH SURFACE



#### AIM AGI86-ND

- With its stainless steel construction, it is long-lasting and easy to use. It is cleanable and hygienic.
- Ergonomic that provides convenience to the user in every aspect. It has a design.
- Device depth is 600 mm.
- The device is a countertop.
- Height adjustable feet on the device available.
- Cooker plate of the device is heat resistant, ST52 steel material with a thickness of 12 mm is produced. Also; Front panel sheet 1mm AISI 304, top plate sheet 1 mm AISI 304, body side sheets 1 mm AISI 430, rear chimney construction closing sheet 1 mm AISI 430, chimney ventilation sheet. Made of 1.5 mm AISI 304 material.
- When the oil reservoir is not emptied when full of oil thanks to the overflow holes in front overflows out of the reservoir and oil inside the device is prevented.
- Easy to remove and clean from the drawer structure.
- Cooker speed as high flame or low flame adjustable, there is 2 gas tap.
- High calorie burners in the device is used.
- Homogeneous heat thanks to each independent burner distribution is provided. Piloted and thermocouple control system is available. Flame thanks to thermocouple. When it goes out, the gas coming to the device automatically cut off.
- Lighter with magneto for pilot light is available.
- Natural Gas (NG) and Liquid Propane Gas (LPG) can work with For this, other gas is included in the spare pouch. Type conversion injectors are available. These the process must be done by a competent person.
- In this product family; Corrugated (Ribbed) and Chrome (CR) coated alternative products are available.



600 SERIES HOT LINE AIM AGI86-ND



## TECHNICAL DATA SHEET

### ÖN / FRONT

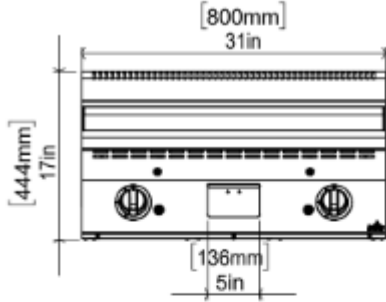

### GENERAL INFORMATION

Model: AIM AGI86-ND  
 Dimension: 800x600x300  
 Net Weight (kg): 71  
 Gaz Enter: R1/2"  
 Cooking Area(mm): 496x596

### SAĞ / RIGHT

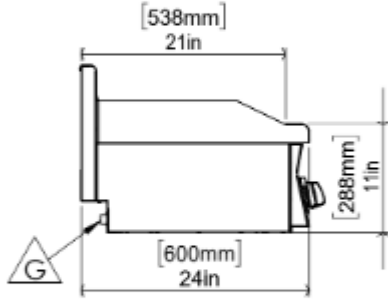

### GAS INFORMATION

NG	G20	G20	G25
	20 mbar	25 mbar	25 mbar
QUANTITY OF HEAT (KW) (HI)	9,4	9,4	9,2
GAS CONSUMPTION	1,030 m3/h	0,960 m3/h	1,108 m3/h

LPG	G30	G30	G30	G31
	30 mbar	37 mbar	50 mbar	37 mbar
QUANTITY OF HEAT (KW) (HI)	9,4	9,5	9,6	9,7
GAS CONSUMPTION	740 g/h	740 g/h	740 g/h	728 g/h

### ÜST / TOP

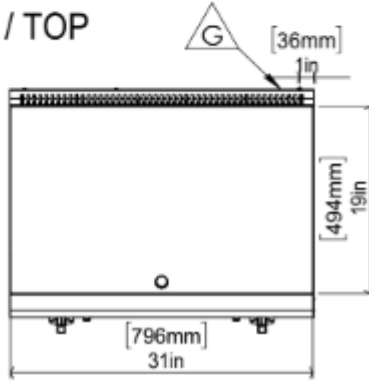

### PACKAGE INFORMATION

Dimension: 900x690x625  
 Package Weight (kg): 88  
 Volume (m<sup>3</sup>): 0,39 m<sup>3</sup>

